



# The TaleSpinner

Westminster Aero Modelers



July 2007

Volume 23

Issue 7

Next Meeting

August 8, 2007

7:30 PM

at the VFW

## EDITOR'S NOTE



### Newsletter:

First, Thank you all for your patience and support as I transition into this new position. Jim did a great job and left me pretty big shoes to fill!

I hope everyone has enjoyed the articles I've been including. This month we have a great article on starting with electrics contributed by our own Bob Deurer.

If you have any ideas for future articles or you have something you like to see published just contact me with the info. I can't guarantee it will show up the following month but we'll get it in.

Please remember that I will continue to post you "For Sale" items in the newsletter and on the web site until you tell me not to.

### Web Site Update:

Some of you may have noticed that the password function on the members page isn't working right now. Please accept my apologies. Apparently as technology marches forward some things get harder. I am scouring the documentation for a fix for this that doesn't involve complicated server-side technologies that I would have no control over.

Currently I only update the site once a month at about the same time I finish the newsletter. I am going to try to update it right after the meeting also so it is a bit more current. Once again, if there is anything you'd like to see posted let me know and we'll try to accommodate you.

Look for more pictures in the near future.  
Best regards for a good flying season.

See you in the pits!

—Mark

### OFFICERS

*President: Jim Hodges 410 875-2669*

*Treasurer: Bob Allen 410 876-3580*

*Vice President: Ed Bradley III 410 635-6436*

*Secretary: Doug Klunk 717 637-8722*

*Member At Large Bill Autry bill\_austry2004@yahoo.com*

### VOLUNTEERS

*Membership: Rich Zaykowski 410 993-2022*

*AMA Liaison: Ed Bradley 410 875-6436*

*Field Marshalls : Spiegle Field - Tom Russell 410-236-6081 weedamen@hotmail.com*

*Baughers Field - : Paul Schaffner 410-429-1911 tripacer@bcpl.net*

*Editor : Mark Eastman 410-549-3972 rcflyer620@gmail.com*

### Inside this Issue:

Minutes 2

Fun Fly Dates 3

Instructor List 3

Electrics! 4-5

FOR SALE 6

Member Information 6

Schedule Of Events 7

Minutes of the WAM Meeting July 3, 2007

By Doug Klunk Secretary

The meeting was called to order by President Jim Hodges @ 7:05 pm. 10 members, were present at Spiegle Field for the meeting.

The Minutes of the June Meeting were accepted as read.

Jim welcomed everyone to tonights meeting and promised to be brief to get back to flying!

Presidents Report –The June Anniversary Fun Fly was very well attended. There was also a reporter and photographer from the Carrol County Times present. Nice front page article followed Monday June 18<sup>th</sup> complete w/ pictures. Nice to see lots of new mwmbers out flying regularly, and thanks for coming to the field tonight!

VP Report – No Report!

Treasurers report – No Report

Field Reports –

Spiegle – Another discussion of millings needed for the access road.

Baughers – Paul discussed moving flight benches out from fence to facilitate easier mower access, possibility of adding a station, or spreading out those there now.

Membership

Carroll County Liaison – No Report

Newsletters – No Report.

Communications – No Report

Instruction/Training – 2<sup>nd</sup> and 4<sup>th</sup> Sunday afternoons at Spiegle Field. Bill reported light turnout for new flyers, would like to open up to Advanced or “Next Step” training of current flyers.

Fun-Flys- Next one is July 15 @ Spiegle

Reminder Spiegle Fun Flies are 2 pm start, 4 pm food

Old Business –

Rich reported that A special Electric Forum Meeting will be in September at the earliest

New Business –None

Member Comments/Announcements-

Walt mentioned he has some engines laying around in need of a plane if anyone was interested – Very happy he joined this club! Very enjoyable Fun Fly's and Good People!.

Steve Brown – Posted the Big Bird Fly in on RCU; AMA Contact this week. Mark discussed adding a separate page on the website if feasible

50/50 – Walt Craig won and promptly returned the money to the treasury!

Meeting adjourned @ 7:50.

Next Meeting August 7<sup>th</sup> VFW @ 7:30pm.

## **FUN FLY DATES**

The Fun Fly dates have been set as follows. As always things are subject to change due to weather etc.

August 19	Baughers Field	9 am
September 9	Pond Fly	Noon
September 23	Spiegle Field	2pm
October 6	Baughers Field	9 am—Big Bird
October 7	Baughers Field	(Rain Date)

## **FLIGHT INSTRUCTION**

With several new members in WAM who may need some help learning to fly, I will continue to provide this list of instructors. The following instructors are available for “flight training” for WAM members. You may call them to arrange a convenient time.

Bill Autry	bill_autry2004@yahoo.com
Bob Allen	410 876-3580
Chris Allport	410 374-5131
Paul Schaffner	410 429-1911
Wendell Richards	410 374-4970
John Sterrett	410 775-2661
Jim Hodges	410 875-2669

## **New Roster**

The latest roster is posted on the web page in the members only area.

## Electrics – How do all the parts go together?

### How much does it cost?

Z3: RC/RC Electric

As interest in electrics increases, so does the confusion of how to get started. It is compounded by the fact that technology is changing overnight and each manufacture has a different nomenclature. Each part has it's own instruction sheet, inside the box, but it's difficult to see how it all goes together until after you buy it all.

I'm no expert, but I've learned from expensive mistakes before I finally got it right. Here's an overview of how these components wire together. This is the setup for brushless motors and Lithium Polymer batteries. It allows throttling up and down, stopping and restarting the motor. (Try that with an engine) LiPo's furnish 3.7volts per cell and you don't have to discharge them before recharging. You can top them off any time. Remember that LiPo's require a special charger.

### Typical RC Setup:

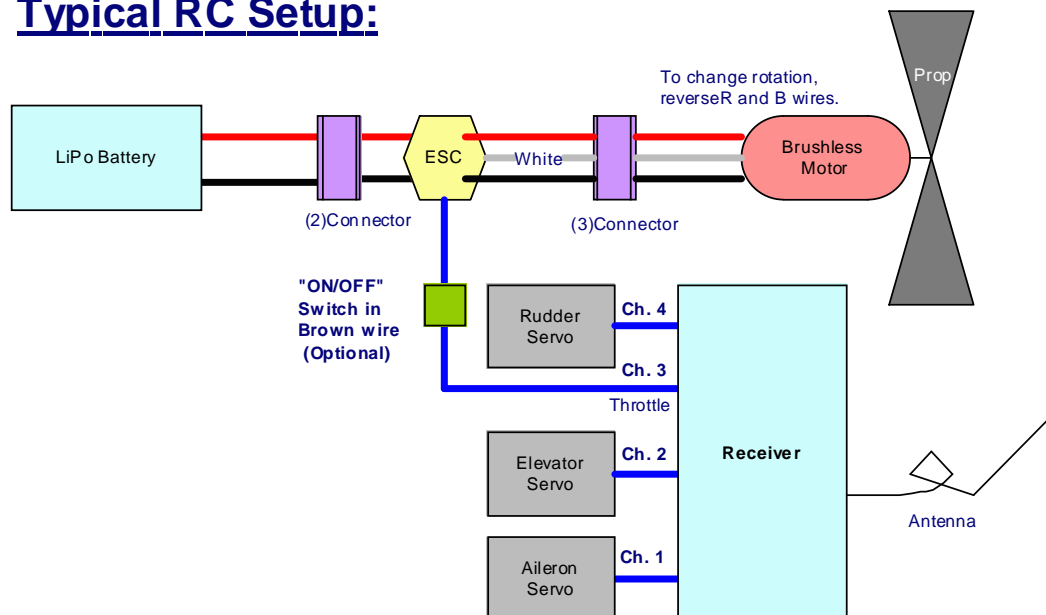

Some controllers come with a switch. If not, a light duty switch can be cut into the brown wire between the ESC and the receiver. The only sure switch is to disconnect the battery immediately after touch down. Be sure to check the motor rotation. To change it, reverse the red and black wires between the ESC and the motor.

**How much does all this cost?** Like everything else there are extremes of how much you want to spend. More is not always better. The following is probably somewhat above the average. I started at the low end of the scale and quickly wanted to upgrade to the next level. I went from \$20 can motors to gear drives and eventually to direct drive brushless motors. I went from Nickel Cadmium batteries to lighter, higher capacity Lithium Polymer batteries. That trial and error left a lot of \$ in my RC junk pile.

**BOM:** (Not including transmitter, receiver and servos, which are the same for engine and electrics)

This setup will fly a 4 pound plane, very aggressively, for about 15 minutes. Good throttle management and even motor "off" can extend this.

- Lithium Polymer Battery: Thunder Power 2100mAh, 20C, 3cell, 11.1volt (North East Sail Plane \$80)
- Brushless Motor: AXI 2820/12 (\$95) (North East Sail Plane combination with ESC \$165)
- Speed Control: Castle Creations Phoenix-45 ESC (\$90)
- Connectors: Deans
- Prop: APC 10x7 Electric (\$3) Electric props are different than engine props.

LiPo battery charger: E-Tec Apache 2500 (Balsa Products \$50)

"It ain't cheap", but there are some ways to help keep costs down a little. First I standardized on the same combination of parts in all of my planes. They're all about 4 pounds, 50 inch wingspan. I've used the same setup in a Traveller 20, Ryan STA and Bonnie 20 and a Tiger Moth. Because electrics don't have to contend with engine vibration, instead of soldering, I've put connectors at every component. I can easily get them out to install in another plane. Second, I've found that some suppliers do offer "combination" prices for ESC and motors, chargers and batteries, etc. That also insures that the parts are compatible. It pays to shop around.

*Bob Deure*



## MEMBER

## Information

**E-MAIL ADDRESSES FOR YOU**

If you have E-mail capability and would like to communicate with other members, use the following addresses for WAM members and our foreign correspondents

**WAM Members**

Allen, Bob	aceallen55@yahoo.com
Allport, Chris	chris.allport@gmail.com.
Bowen, Ron	ronrose-b@juno.com
Bradley, Ed	encb3@bellatlantic.net
George Davis	glddb2@verizon.net
Bob Donohue	ultimateflyer@aol.com
Eastman, Mark	rcflyer620@gmail.com
Gray, Augie	asgjrg@msn.com
Faulkner, Bud	<a href="mailto:deenbud@comcast.net">deenbud@comcast.net</a>
Hodges, Chris	spaceexplorer3000@yahoo.com
Hodges, Jim	rcjim@comcast.net
Johnston, Dale	dalejohn@ccpl.carr.org
Klunk, Doug	<a href="mailto:dougrus@comcast.net">dougrus@comcast.net</a>
Miles, Ray	rkmiles@carr.org
Omanski, Louis	lomansky@ringlerassociates.com
Peacock, Milt	<a href="mailto:rcpilot2505@comcast.net">rcpilot2505@comcast.net</a>
Renick, Bill	billylee8@verizon.net
Russel, Tom	weedamen@hotmail.com
Schaffner, John	pumexim2@bcpl.net
Schaffner, Paul	tripacer@bcpl.net (*)
Jeff Smith	<a href="mailto:jefran@comcast.net">jefran@comcast.net</a>
Sterrett, John	jsterret24@yahoo.com
Zaykoski, Richard	zaykoski@carr.org

**Foreign Correspondent**

Nick Jonckheere/Belgium  
nickjonckheere@hotmail.com

**ANYONE WHO WOULD LIKE THEIR E-MAIL ADDRESS PLACED HERE  
LET ONE OF US KNOW  
SEND CORRECTIONS TO MARK**

**(\*) NEW ADDRESS**

**FOR SALE**

For Sale: Byron Originals 1/4 size Ryan STA. Kit is mostly framed up, flap linkage remains to be installed, kit is 100% complete with plans, instruction book and decals. \$400.00

Dale Johnston [dalejohn@ccpl.carr.org](mailto:dalejohn@ccpl.carr.org)

For Sale: Patriot XL \$100.00

55" wingspan Engine mount and all pushrods in place. Covered in gray with red, white, and blue trim. Required engine = .60 to .90 2-stroke.

Install engine and fly!

Milt Peacock 410-833-3122

**NEW MEMBERS**

No new members this month

# August 2007

Sun	Mon	Tue	Wed	Thu	Fri	Sat
			1	2	3	4
5	6	7	8	9	10	11
						BAA Robotics Competition
12	13	14	15	16	17	18
Training Day						
19	20	21	22	23	24	25
Fun Fly						
26	27	28	29	30	31	
Training Day						



## Schedule of Events

### WAM Events

Aug 7, 2007 Meeting 7:30 @ Spiegle

Fun Fly Aug 19

Training days Aug 12 and 26 at Spiegle Field 1 PM

### Non WAM Events

## THE TALESPIINNER

Newsletter of the

Westminster Aero Modelers  
c/o Mark Eastman  
1622 Heather Hts.  
Eldersburg, MD 21784

Anyone Wishing To Submit  
Material For The TaleSpinner  
Should Use Regular Mail To The  
Address Above Or Via Email To:

rcflyer620@gmail.com

**We're on the  
web at:**

[www.flywam.org](http://www.flywam.org)

This issue of  
The Talespinner  
was printed, folded, stapled,  
and mailed courtesy of  
Lou Omansky.  
WAM thanks Lou for his  
efforts!



The **WESTMINSTER AERO  
MODELERS** meet on the First  
Tuesday  
of every month, unless otherwise  
noted, at 7:30 p.m.  
in the VFW HALL on Poole Road in  
Westminster.

**VISITORS ARE WELCOME !!!**

Materials and opinions published in The Talespinner are those of the author and do not necessarily reflect those of the Westminster Aero Modelers or the Editor. Every attempt is made to assure that the information contained herein is accurate, but the Westminster Aero Modelers and the Editor are not responsible for errors or omissions. No responsibility is assumed, expressed, or implied as to the suitability, safety, or approval of ANY material in this Newsletter. Any party using ANYTHING expressed herein does so at his/her own risk and discretion without recourse against anyone. Contributions to The Talespinner are welcome! Credit will be noted and given when due. The Editor reserves the right to reject or edit material submitted for publication. Permission for reprinting or quoting items in The Talespinner is granted providing that credit is given to both the author and to The Talespinner.  
— Editor

**To:**

